

## INSTRUCTION MANUAL

### ADSL Central Filter(SM SRS-2415A) & In-Line Filters(SM SMF-2001C)

Thank you for purchasing this product.

The " instruction manual " shows you how to use this product safely.

Before putting this product to use, please read this manual carefully to fully understand the contents.

In addition, after you read this, please be sure to keep this in the place where it is easily found at anytime.

#### Warning

- Except the competent repair technician, please do not try to disassemble, repair or remodel this product. It may cause fire and/or electric shock.
  - ( Please do not pour liquid such as water onto this product, and do not mix this product with foreign matters or chemicals. It may cause fire and/or electric shock
  - ( Please do not drop the product, and do not give strong impact on this product. It may cause fire and/or electric shock.
  - ( If you fell strange heat, smoke or smell or hear strange sound from this product, and please stop using this product and disconnect the telephone by pulling out the telephone cord immediately. Continuous use may cause fire and/or electric shock.
- When there is a possibility of a thunderbolt, please disconnect the telephone by pulling out the telephone cord.  
And, please do not touch the cables and/or this product at the time of thunderbolt.  
The built-in thunderbolt prevention device is provided in this product. Nevertheless, for double safety reason it is recommendable.
  - ( Please do not place heavy matter on or do not trample this product. It may cause damage to the product, and/or injury the person.
  - ( Please do not use this product in the moisture or at the place where humidity is high. It may cause fire and/or electric shock.

#### Caution

- The product is the device provided for service of ADSL and in order to join the service, please contact the ADSL service provider.
- There are sometimes such instances that communication speed significantly decreases or communication is completely stopped due to circumstances of the ADSL circuit or the influence of the equipment that is not properly connected for communication.
- Please acknowledge beforehand that for any of consequential damages due to breakdown, erroneous operation of this product and/or any type of troubles the supplier of this product is not responsible at all
- In case of multiple uses of several in-house telephones with branch lines, an IN-LINE FILTERS(SM SMF-2001C) must be incorporated each line for simultaneous use with ADSL service, except where the ADSL (SM SRS-2415A) is connected.  
Otherwise, there is a possibility of disturbances on the data. (Please refer to the illustration for connection method below.)
- This product is specified for use in Australia. Therefore it cannot be used outside this country.  
The supplier of this product is not responsible for consequences arising from the use outside this country

## INSTRUCTION MANUAL

### ADSL Central Filter(SM SRS-2415A) & In-Line Filters(SM SMF-2001C)

Thank you for purchasing this product.

The " instruction manual " shows you how to use this product safely.

Before putting this product to use, please read this manual carefully to fully understand the contents.

In addition, after you read this, please be sure to keep this in the place where it is easily found at anytime.

#### Warning

- Except the competent repair technician, please do not try to disassemble, repair or remodel this product. It may cause fire and/or electric shock.
  - ( Please do not pour liquid such as water onto this product, and do not mix this product with foreign matters or chemicals. It may cause fire and/or electric shock
  - ( Please do not drop the product, and do not give strong impact on this product. It may cause fire and/or electric shock.
  - ( If you fell strange heat, smoke or smell or hear strange sound from this product, and please stop using this product and disconnect the telephone by pulling out the telephone cord immediately. Continuous use may cause fire and/or electric shock.
- When there is a possibility of a thunderbolt, please disconnect the telephone by pulling out the telephone cord.  
And, please do not touch the cables and/or this product at the time of thunderbolt.  
The built-in thunderbolt prevention device is provided in this product. Nevertheless, for double safety reason it is recommendable.
  - ( Please do not place heavy matter on or do not trample this product. It may cause damage to the product and/or injury the person.
  - ( Please do not use this product in the moisture or at the place where humidity is high. It may cause fire and/or electric shock.

#### Caution

- The product is the device provided for service of ADSL and in order to join the service please contact the ADSL service provider.
- There are sometimes such instances that communication speed significantly decreases or communication is completely stopped due to circumstances of the ADSL circuit or the influence of the equipment that is not properly connected for communication.
- Please acknowledge beforehand that for any of consequential damages due to breakdown, erroneous operation of this product and/or any type of troubles the supplier of this product is not responsible at all
- In case of multiple uses of several in-house telephones with branch lines, an IN-LINE FILTERS(SM SMF-2001C) must be incorporated each line for simultaneous use with ADSL service, except where the ADSL (SM SRS-2415A) is connected.  
Otherwise, there is a possibility of disturbances on the data. (Please refer to the illustration for connection method below.)
- This product is specified for use in Australia. Therefore it cannot be used outside this country.  
The supplier of this product is not responsible for consequences arising from the use outside this Country

## 1. Specification summary

Model	SM SRS-2415A
ADSL specification	AS/ACIF S002: 2001
External size	47.0(W) × 44. 0(D) × 24. 5(H)
Weight	48.5 g
Operational requirement	Temperature:0~40°C Humidity:20~80%

Model	SM SMF-2001C
ADSL specification	AS/ACIF S002: 2001
External size	55.86(W) × 24.41(D) × 22. 67(H)
Weight	25.5 g
Operational requirement	Temperature: 0~40°C Humidity:20~80%

## 2. Connection method

*In case of multiple uses of several in-house telephones via branch lines*

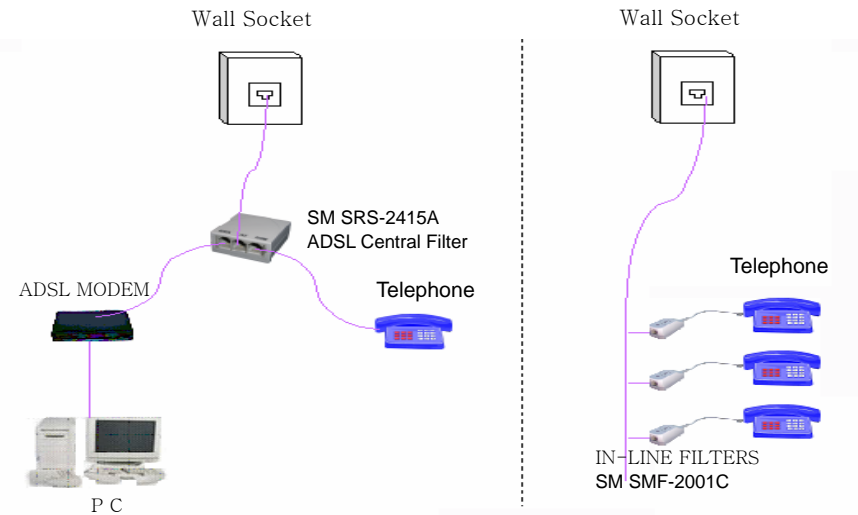

## 1. Specification summary

Model	SM SRS-2415A
ADSL specification	AS/ACIF S002: 2001
External size	47.0(W) × 44. 0(D) × 24. 5(H)
Weight	48.5 g
Operational requirement	Temperature:0~40°C Humidity:20~80%

Model	SM SMF-2001C
ADSL specification	AS/ACIF S002: 2001
External size	55.86(W) × 24.41(D) × 22. 67(H)
Weight	25.5 g
Operational requirement	Temperature: 0~40°C Humidity:20~80%

## 2. Connection method

*In case of multiple uses of several in-house telephones via branch lines*

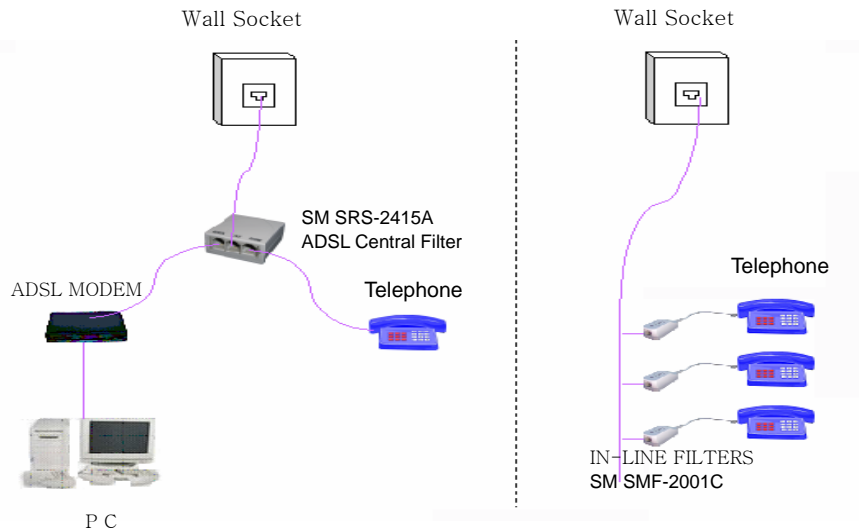

3. For inquiry on this product, please contact either  
SUNMYUNG ELECTRO-TELECOM CO., LTD. or regional distributor.



SUNMYUNG ELECTRO-TELECOM CO., LTD.

<http://www.sunmyung.com>

e-mail : sunmyung@sunmyung.com

TEL: +82.31.943.8525 (EXT.225)



SUNMYUNG ELECTRO-TELECOM CO., LTD.

<http://www.sunmyung.com>

e-mail : sunmyung@sunmyung.com

TEL: +82.31.943.8525 (EXT.225)